

AREA CLASSIFICATION IS NOT DIFFICULT (TO MAKE A MESS OF)

Johannes Auret, Explolabs Consulting

1 Introduction

Area classification (called classification of hazardous locations in our mines) is quite simply, the most important part of explosion prevention. It is the basis for all further efforts and will therefore lead to affordable safety or less-affordable unsafe conditions, even if only because a wrong decision is an expensive decision.

I want to make a radical statement: Correct area classification leads to affordable explosion prevention.

Why then, are many operations never taken through the next steps after a classification ? It almost seems that there is a belief that the classification itself gives protection. Not so! The classification is only a tool; it forms the basis for putting the correct equipment, installations and maintenance practices in place. The real effort starts after the classification.

I believe it is (a) because the classification is often unrealistic or at least perceived to be, and (b) because the technical staff simply does not have in-house expertise to apply the classification information, that no further progress is made in so many instances.

This paper tries to give direction on some problem areas of the classification process.

2 Aim of Classification

The basic aim of area classification is to support the correct selection of Ex equipment. The following inputs to Ex equipment selection are determined:

- ◆ **The applicable zones applicable, i.e. the probability of explosive atmospheres being present.**

An increased probability raises the probability of an explosion and requires potential ignition sources to be more strictly controlled, by using explosion protection techniques less prone to failures causing ignition.

These days, the required Equipment Protection Level (EPL) must be identified but mostly has a simple relationship with the zones.

- ◆ **To determine ignition properties of explosive atmospheres.**

Explosion protected apparatus as an energy source is still capable of igniting, even under normal operation, certain explosive atmospheres. Explosion protected apparatus must be selected that will not ignite explosive atmospheres in which they are used, as inferred from the

the ignition properties e.g. gas group and temperature class. These ignition properties are normally established as part of the classification process.

3 Application of Zone Classification

The principle of increased apparatus protection to offset more frequent exposure of such apparatus to explosive atmospheres has been defined. The table below gives an overview of the probability of an explosive atmosphere for the various zones and the corresponding level of protection required:

Flammable material	Hazardous location	Frequency and duration of explosive atmosphere	Level of protection required	Explosion protection techniques allowed¹
Gas/vapour	Zone 0	Continuous	Very high	Ex ia, Ex ma, double protection
	Zone 1	Normal operation	High	Above plus Ex ib, mb, d, e, px, py, q, o
	Zone 2	Abnormal operation	Safe in normal operation	Above plus Ex pz, Type "n"
Dust	Zone 20	Continuous	Very high	tD A20, tD B20 (IP65 enclosures), iaD, maD
	Zone 21	Normal operation	High	Above plus tD A21, tD B21 (IP65 enclosures), ibD, mbD
	Zone 22	Abnormal operation	Safe in normal operation	Above plus tD A22, tD B22 (IP65 enclosures)
Underground coal mine	Compulsory hazardous locations	Normal operation	Very high	Ex ia, Ex ma, double protection
			High + Isolate when ventilation fails	Above plus Ex ib, mb, d, e, px, q, o

NOTE 1. The alternative marking format of SANS 60079-0 Edition 4: 2009 (IEC 60079-0 Edition 5: 2007) has been used in the table, as it includes the EPLs. Readers must note that equipment marked according to older versions of SANS 60079-0 is and will still be in circulation for a considerable period.

The following conclusions can be drawn from the table:

- a) Only a few types of Ex apparatus can be safely used in a Zone 0 or Zone 20.
- b) Apparatus protection suitable for Zone 1 is also suitable for compulsory hazardous locations in coal mines. However, the apparatus must be certified for group I, temperature class T1 (but 150°C in the presence of coal dust) or better.
- c) Apparatus suitable for Zone 0 is also suitable for Zone 1 and Zone 2, and apparatus suitable for Zone 1 is also suitable for Zone 2.



Figure 1: Ex equipment must be suitable for the explosive environment

4 Classification Concepts

Practical area classification for gas explosive atmospheres is simplified if one of the following methods is followed, where possible:

- a) Classification of hazardous locations by direct example, which is a method that applies to standard installations. For example, vehicle refuelling stations.
NOTE - Care should be taken to ensure that the same products and conditions apply.
- b) Classification based on well-known sources of release and ventilation levels; a few examples of this method are included in SANS 60079-10.
- c) Alternatively, calculations based on dispersion theory may be employed.

For dust explosive atmospheres, typical examples as well as sources of release are considered.

6 Available Standards and Application

Approved standards must be used for the classification of hazardous locations, i.e. those listed in or meeting the requirements of Clause 4.4 of SANS 10108 Edition 5: 2005.

SANS 10108 requires that preference is given to IEC (international) standards where such a standard is suited to the type of plant to be classified. This means that IEC/SANS 60079-10 (flammable gases and vapours) and IEC/SANS 61241-10 (combustible dusts and fibres) are therefore the primary standards to be used.

NOTE – These standards are currently being re-numbered to respectively IEC/SANS 60079-10-1 and IEC/SANS 60079-10-2.

However, IEC/SANS 60079-10 only gives the main principles of area classification. For detailed recommendations regarding the extent of the hazardous areas in specific industries or applications, reference must be made to the standards relating to those industries. We may consider classification based on recognized industry-specific standards to comply with IEC/SANS 60079-10 and therefore SANS 10108, provided they use the same classification principles as in IEC/SANS 60079-10. Some such standards are listed in SANS 10108. A more comprehensive list is shown below.

United Kingdom

- Institute of Petroleum, Model Code of Safe Practice, Part 9 “Liquefied Petroleum Gas”
- Institute of Petroleum, Model Code of Safe Practice, Part 15 “Area Classification Code for Petroleum Installations”, Editions 1 to 3 (IP Part 15 for short)
- LP Gas Association’s Code of Practice 1-1 “Code of Practice 1: Bulk LPG Storage at Fixed Installations, Part 1: Design, Installation and Operation of Vessels Located above Ground”
- LP Gas Association/Institute of Petroleum Technical Memorandum No 70: 2000 “Storage and Dispensing of LPG as an Automotive Fuel at Petrol Filling Stations”
- HSE Health and Safety Series Booklet HS(G)41: 1990 “Petrol Filling Stations: Construction and Operation”
- Institute of Gas Engineers, IGE/SR/25 “Hazardous Area Classification of Natural Gas Installations”

United States of America

- American Petroleum Institute Recommended Practice 500 “Recommended Practice for Classification of Locations for Electrical Installations at Petroleum Facilities Classified as Class I, Division 1 and Division 2”
- American Petroleum Institute Recommended Practice 505 “Recommended Practice for Classification of Locations for Electrical Installations at Petroleum Facilities Classified as Class I, Zone 0, Zone 1 and Zone 2”
- NFPA 497 “Recommended Practice for the Classification of Flammable Liquids, Gases, or Vapors and of Hazardous (Classified) Locations for Electrical Installations in Chemical Process Areas”
- NFPA 52 “Compressed Natural Gas (CNG) Vehicular Fuel Systems”
- NFPA 30 “Flammable and Combustible Liquids Code”
- NFPA 58 “Standard for the Storage and Handling of Liquefied Petroleum gases”

Australia and New Zealand

- AS/NZS 2430 “Classification of hazardous areas”

South Africa

- SANS 10108 “The Classification of Hazardous Locations and the Selection of Apparatus for Use in Such Locations”
- SANS 10087 series “The Handling, Storage and Distribution of Liquefied Petroleum Gas in Domestic, Commercial, and Industrial Installations”
- SANS 10089 series “The Petroleum Industry”
- IEC/SANS 60079-10 “Electrical Apparatus for Explosive Gas Atmospheres, Part 10: Classification of Hazardous Areas”
- IEC/SANS 61241-10 “Electrical Apparatus for use in the Presence of Combustible Dust, Part 10: Classification of Areas where Combustible Dusts are or may be Present”

European Community

- EN/IEC 60079-10 “Electrical Apparatus for Explosive Gas Atmospheres, Part 10: Classification of Hazardous Areas”
- EN 50281-10 “Electrical Apparatus for Use in the Presence of Combustible Dust, Part 3: Classification of Areas where Combustible Dusts are or May be Present”

International/IEC

- IEC 60079-10 “Electrical Apparatus for Explosive Gas Atmospheres, Part 10: Classification of Hazardous Areas”

- IEC 61241-10 “Electrical Apparatus for use in the Presence of Combustible Dust, Part 10: Classification of Areas where Combustible Dusts are or may be Present”

Some of the most widely used standards are reviewed in terms of their area of application and approach to area classification in the table below.

Table 1: Comparison of various national/international classification standards

Country/ region	Reference	Scope	Comments
RSA	SANS 10108	Flammable gases, vapours, mists, dusts.	Direct example, reference.
	SANS 60079-10	Flammable gases, vapours, mists.	Some direct examples, first principles, reference.
	SANS 10087 series SANS 10089 series SANS 61241-10	LPG. Petroleum. Explosible dusts and fibres.	Refers to SANS 10108. Direct example.
Internatn'l (IEC)	IEC 60079-10	Flammable gases, vapours, mists.	Some direct examples, first principles, reference.
	IEC 61241-10	Explosible dusts and fibres.	
North America	API RP 500, 505	Petrochemical	Direct example, source of release
	NFPA 58 NFPA 497	LPG Chemical	Direct example Direct example, source of release
UK	IP Code Part 15 Ed 3	All plants.	Direct example, source of release, risk-based approach.
	LPG COP 1-1 and TM70	LPG.	Direct example.

A comparison of various standards show a phenomenon that comes as no surprise but could be frustrating and confusing if not understood: The classification results, and in particular the size of zones, will often differ. The zone sizes specified in a standard depends on

- How conservative the approach was that was taken. This goes hand-in-hand with the age of the standard (older standards tending to be more conservative).
- Another age-related factor is that modern technologies produce cleaner plants with fewer and smaller releases, due to better sealing systems, restrictions on emissions and more reliable equipment requiring less maintenance.
- How general the application of the standard is (the more general, the more conservative the approach tends to be).
- The interpretation of the classifier also plays a role.

In conclusion, the logical choices for standards for general classification are IP Code

Part 15 Edition 3 for gases and vapours and SANS 61241-10 for dusts, as these standards cover

- **all industries**
- **all classification techniques**
- **compliance with SANS 10108.**

Area classification for specific installations may be based on other standards included in the above list, but be careful not to “mix and match”. There must be a main standard forming the classification backbone.

7 Classification Framework for Gas Locations

In practice, the following nine steps can be followed.

1. List flammable materials.
2. Select those present in significant quantities.
3. Determine sources of release.
4. Determine grades of release.
5. Determine zones (0/1/2); i.e. areas where explosive atmospheres occur.
6. Size and shape zones.
7. Rationalize.
8. Determine Equipment Protection Level (EPL).
9. Properties of explosive atmospheres, especially ignition (Group and Temperature Class).

8 Classification Framework for Dust Locations

In practice, the same steps as for gases, except rationalization, are followed.

1. List flammable materials.
2. Select those present in significant quantities.
3. Determine sources of release.
4. Determine grades of release.
5. Determine zones (20/21/22); i.e. areas where explosive atmospheres occur, plus fire hazards.
6. Size and shape zones.
7. Properties of explosive atmospheres.

9 Methods of reducing dust explosion risk

The following methods can be used to reduce the possibility of forming an explosive dust atmosphere or dust layers that can ignite or form clouds when disturbed, in which case a less hazardous zone can be allocated:

Dust suppression and extraction systems.

Inerting of dust atmospheres.

Housekeeping/cleaning.

10 Team approach

Classification of hazardous locations should only be undertaken by well experienced, multi-disciplinary teams. The Occupational Health and Safety Act, 1993 (Act 85 of 1993) and the Mine Health and Safety Act, 1996 (Act 29 of 1996) both require the owner (user) of the plant or mine to classify potentially hazardous locations (in the latter Act, some compulsory hazardous locations are specified), and as such it is the owner's responsibility to ensure that hazardous location studies be undertaken at regular intervals to ensure that all modifications to the plant or mine that could affect the hazard are taken into account.

Technically, the Process, Electrical/Instrumentation and Mechanical disciplines will be required to contribute. In an existing, operational factory of medium size, this means typically the process engineer, production manager, maintenance manager and senior staff. It is beneficial to also involve the safety (SHEQ) discipline and projects staff.

The role of a Master Installation Electrician (MIE) is often queried. The OHS Act makes it very clear that the MIE's legal function is to issue the electrical Certificates of Compliance (CoCs) for hazardous area installations. He has to understand how to interpret an area classification, of course, as suitable Ex equipment is selected based on the area classification.

Expertise on the classification process is mostly available from the few organizations that employ specialists in area classification. Their role is to steer the classification process so that (a) the correct information can be extracted from the team members and (b) the classification standards can be applied to this information to produce the correct result. In most cases, options for classification (e.g. improved ventilation versus better protected equipment) must be identified and carefully considered, as the cost and practical operation of a plant will be affected by the decision taken.

11 Information required

For a new plant, ample documented information is mostly available, e.g. a process description, plot plan or site layout, process flow diagrams (PFDs), process and instrumentation diagrams (P&IDs) and material safety data sheets (MSDSs).

For existing plants, this information is often not available. Existing area classification information is out of date and limited to drawings, often a plan view with no cross-sections. Fortunately, a skilled area classification specialist will be able to find this information, even if it means to record information available verbally from long-serving staff members.

12 Records

It is strongly recommended that the classification study be fully documented. The documentation should cover all issues considered in deciding on the final classification. All assumptions, approximations and calculations made should be included so as to ensure full traceability of the process at a later stage.

Hazardous location drawings

12 The “idiot’s guide” to classification

This title is unfair, because anybody taking the trouble to read this far is definitely not an idiot!

Here’s the scenario: You are responsible for a plant that contains flammable gases, liquids and/or solids. What now ?

Let us look again at the basic steps:

1. *List flammable materials*

This is easy. The SHEQ people already have them ! If in doubt, look at the MSDS of the raw materials. If there are no MSDSs for final products, it is your companies fault; take action !

2. *Select those flammables present in significant quantities*

Typically, there will be less than 10 substances in this category. A few **pointers**: For mixtures containing flammable and non-flammable materials, use a rule of thumb, e.g. that liquid mixtures with less than 30% by mass flammables and gas mixtures with less than 10% by volume flammables, are not flammable. Use the properties of the flammables that make up at least, say, 75% of the mixture. Use the worst-case values or, if this is too strict, use the weighted-average values. Use these to determine parameters such as gas group and temperature class. Obviously, for mixtures you need info on the pure substances in the mixture (Example – Butane is a pure substance; petrol is a mixture of butane and other pure substances.); SANS 60079-20 is an excellent source document.

3. *Determine sources of release*

NB: A source of release is an equipment feature that will normally (e.g. vents, samples points and oily water sewers) or under abnormal plant conditions (leaking of seals and gaskets or rare events e.g. a release due to start-up after a maintenance shutdown) expose a flammable material to atmosphere (air) and where the flammable material forms explosive mixtures in air.

Example - An open drum of grease at ambient temperature does not form an explosive atmosphere because the flash point is too high. The grease surface is therefore NOT a source of release. However, a drum of petrol will be a source of release. **Pointer**: Substances handled at ambient temperature and with flash points higher than 55°C will generally not form explosive atmospheres, or will form very limited volumes of explosive atmospheres where the substance is a mixture, i.e. consists of more and less volatile materials (high volatility = low flash point and boiling point).

4. *Determine grades of release*

Each source of release is associated with at least (and normally only) one grade of release. One gets secondary (typically, up to 10 hours in total per year) primary (more than 10 and up to 1000 hours in total per year) and continuous (more than 1000 hours in total per year) grade. **Pointer**: It is rare to have more than one grade of release for the same source. One example is a pump fitted with a single mechanical seal, because small quantities of product are normally lost to lubricate the seal surfaces; a rare broken seal will occasionally release larger amounts.

5. Determine zones (0/1/2)

This depends strongly on ventilation. In open air, secondary, primary and continuous grades of release create respectively Zone 2, 1 and 0 areas. Ventilation less than in open air is described in IP Part 15 as adequate or inadequate. Adequate ventilation means that a single short release of flammable material will be diluted to below the lower explosive limit within 10 minutes and is found in so-called “sheltered” areas. A uniform ventilation rate of at least 12 air changes per hour, with no dead spots is required. The volume of the explosive atmosphere will normally increase. If this ventilation rate is not achieved (inadequate ventilation), the area is “enclosed” and a more severe zone applies.

6. Size and shape of zones

Shape: These days a simplified model is proposed, as follows. In the case of pressurized releases, gravity effects are overridden by the pressure driving force. In free space, the explosive atmosphere takes the form of a ball or sphere; the sphere gets flattened where solid obstacles like walls and ground are intercepted. **Pointer:** The effect of wind direction is already covered, i.e. the sphere is sized to cover this; remember that increased wind speed also causes increased dilution rate. In the case of atmospheric-pressure releases, lighter-than-air gases/vapours normally quickly dilute (unless there is a solid ceiling); heavier-than-air releases collect in below-grade structures e.g. sumps, sewers, pits, bunds or enclosed spaces e.g. sewer systems and therefore take on the size and shape of the containing structure. **Pointer:** As a rule of thumb, a below-grade structure will be a restricted-ventilation area (meaning that the available space is totally flooded by the gas/vapour) if the depth-to-width ratio is more than 1 in 6. **Pointer:** Of the common gases, only a few such as hydrogen, methane and ammonia are lighter than air, with carbon monoxide being almost neutral.

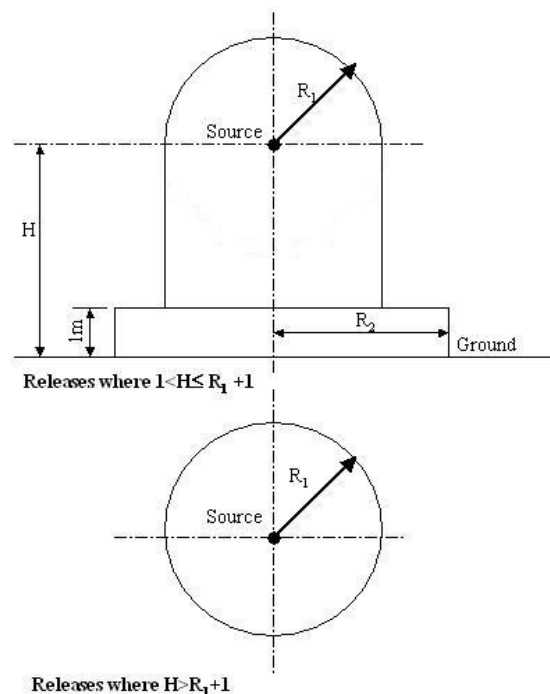

Size: In other words, the volume of the explosive atmosphere. The outer limit is where the concentration of flammable material dips below the lower explosive limit. For atmospheric releases, this size is a balance between Rate of vaporization (dependent on volatility i.e. flash point and boiling point of liquid) and Rate of dilution (ventilation). If the gas/vapour is heavier than air (of the common gases only hydrogen, methane and ammonia are lighter than air, with carbon monoxide being almost neutral), we already know that the explosive atmosphere may collect in hollows and enclosures and take on the size and shape of the containing structure.

Pointer: On rare windless days, explosive atmospheres can form “trails” and migrate for considerable distances. As a rule of thumb, a wind speed of 3m/s is needed to provide effective mixing and dilution. Open air is considered to provide rarely less than 0,5m/s and frequently more than 2m/s.

For pressurized releases, Rate of release (pressure dependant) must additionally be considered, and the size of the explosive atmosphere is a balance between these three factors (assuming a long term, constant release, of course).

But what size can be practically expected for pressurized releases? As already stated, a number of factors will affect the size. For gases/vapours, the classification standards state that equipment with a larger than 30m hazard radius is unacceptable. Most of us will agree, as high product losses and pollution levels will make this non-viable. A few examples of “typical” radii are shown below.

Equipment	Flammable substance	Hazard radius in meters (assuming spherical HA)
Small centrifugal pump with single mechanical seal and throttle bush	Liquid (petrol)	≤ 5
Small pump with single seal	LPG	≤ 5
Flanged joint	Liquid (petrol)	1.5
Flanged joint	Gas	1
Sampling point, drain into sample bottle	Liquid (petrol)	2.5
Sampling point, drain into sample bomb, open purge	Liquid (petrol)	2
Sampling point, drain into sample bomb, closed-loop purge	Liquid (petrol)	~0
Tank vent	Liquid (petrol)	2-3
Process vent	Gas/vapour	5-9

NOTE – These values are for illustration purposes only.

7. Rationalize

This simply means that a typical classification meets the “raisin cake” model: Isolated Zone 1 (outside vessels) and Zone 0 (mostly inside vessels) pockets in a Zone 2 matrix (justified by the combination of releases from hundreds of secondary sources of release).

8. Equipment Protection Level (EPL)

A new role of the classification team is to determine the EPL. Normally a simple relationship as follows will exist.

Zone	Minimum Equipment Protection Level (EPL)
0	Ga
1	Gb
2	Gc
20	Da
21	Db
22	Dc

However, occasionally there will be risk factors justifying a different EPL.

9. Properties of explosive atmospheres

This involves flame/spark ignition and temperature/hot surface ignition, considered separately because these are different mechanisms of ignition. This means that no relationship exists; for example, hydrogen ignites easily with a spark but requires high temperatures; carbon disulphide ignites easily with either a spark or a hot surface.

The relevant parameters and derived (simplified) parameters are

Environment	Minimum ignition energy	Gas, vapour or dust (sub)division
Underground mines	250 μ J	I
Gas and vapour, Surface	180 μ J	IIA
	60 μ J	IIB
	20 μ J	IIC
Dust, Surface	<x	IIIA
	<<x	IIIB
	<<<x	IIIC

and

Ignition temperature of gas or vapour (°C)	Temperature class required by the area classification (Not used for Group III)
>450	T1
>300	T2
>200	T3
>135	T4
>100	T5
>85	T6

Next, flammable (combustible) dusts.

The basic steps are as follows:

1. *List of flammable materials*

The MSDS will normally have little information on flammability and explosivity. It is worthwhile to remember that most organic and metallic solid fines are flammable and a potential explosion hazard. The condition of the particles (size, shape, oxidation, moisture content etc.) plays an important role. Often, samples of the material may need to be tested to get an accurate indication of explosivity.

2. *Select those flammables present in significant quantities*

Typically, solid material with particle sizes less than 0,5mm can participate in an explosion. Such fines will occur due to bulk material handling. The frequency and effectiveness of any cleaning operations must be carefully considered.

3. *Determine sources of release*

NB: A source of release is an equipment feature that will release fines to atmospheric air and create an explosive atmosphere. This can happen inside equipment (the containment system) or outside equipment. **Pointer:** Dust must be in suspension (must form dust clouds) to be explosive.

Examples are a mill interior or a pneumatic transport system (internal) or a bag filling operation (external).

It must be ensured that the dust-air mixture is indeed in the explosive range. The lower explosive limit/concentration for dust-air mixtures is generally between 30 and 40 g/m³. A useful rule of thumb is that a dust cloud is explosive if a 40W incandescent lamp is invisible to the eye at a range of 3m. Loosely translated, this means that the dust cloud is dense enough to prevent normal human operation in the area.

Suspended dust inside dust-generating or dust-handling equipment will pretty much always be in the explosive range, due to being (a) enclosed, (b) continuously disturbed and (c)

continuously supplied with freshly generated dust. Zone 21 locations mainly involve areas associated with but outside of the dust-containment system (ie in the open air) and where dust will be put in suspension by a secondary operation.

Note that a Zone 21 location (unlike a Zone 20 locations) does not have an enforced boundary; the boundary is determined by the distance from the source of release it takes for the dust to settle sufficiently to drop below its explosive range. This distance is generally taken to be 1m.

4. *Determine grades of release*

As for gases, one gets secondary primary and continuous grade releases, defined as follows.

- a) continuous formation of a dust cloud: locations in which a dust cloud may exist continuously, or may be expected to continue for long periods or for short periods which occur frequently;
- b) primary grade of release: a source can be expected to occasionally release combustible dust in normal operation;
- c) secondary grade of release: a source which is not expected to release combustible dust during normal operation; if it releases, it is likely to do so only infrequently and for short periods only.

These definitions are the formal ones but fail to point out clearly that an explosive dust cloud must result.

5. *Determine zones (20/21/22)*

Pointer: Unlike as for gases, the zones for dusts are best determined following the “Cremora” rule: If the dust clouds are inside, it is a Zone 20. If they are outside, it is Zone 21. If there are dust layers on top of equipment, it is Zone 22. Note that this is a broad approach and not a hard-and-fast rule.

6. *Size and shape of zones*

Internal explosive atmospheres take the form of the enclosure. External explosive atmospheres are normally shaped according to the shape of the source of release, varying from a true point (such as a bag filling point) creating a spherical explosive cloud, to a cloud that fills a smallish room. **Pointer:** The hazard radius is often 1m, from practical experience.

7. *Equipment Protection Level (EPL) As for gases.*

8. *Properties of explosive atmospheres*

This involves flame/spark ignition and temperature/hot surface ignition, considered separately because these are different mechanisms of ignition. The relevant parameters are Group, Cloud Minimum Ignition Temperature, and Layer Minimum Ignition Temperature. Layer ignition needs to be prevented because layers can be disturbed and form explosive clouds, but also because layers are ignited at lower temperatures than clouds and can act as a cloud ignition source. The relevant Group parameters are:

Environment	Materials	Minimum ignition energy	Gas, vapour or dust (sub)division
Underground mines	Coal dust	<<<x	I
Dust, Surface	Combustible flyings	<x	IIIA
	Non-conductive dusts	<<x	IIIB
	Conductive dusts	<<<x	IIIC

13 In conclusion

An effort has been made in this article to give a practical approach to area classification. Using this approach, the average technical person can accurately establish whether he/she has an explosion hazard and even the nature of the hazard. It is recognized that there will be some applications requiring more expertise in terms of properties of flammable mixtures, selection of classification standards and establishing the type of zones and the size of zones (especially where ventilation is restricted).

Once an area classification has been determined, this information must be put to work to ensure that the equipment and installation will not cause explosions. Being a thorny issue especially for existing plants, this subject may be addressed in follow-up publications.